

# PARADIGM

## Low port count package background

Packaging Workshop  
Eindhoven

7<sup>th</sup> July 2011

# Gooch & Housego Standard Package support

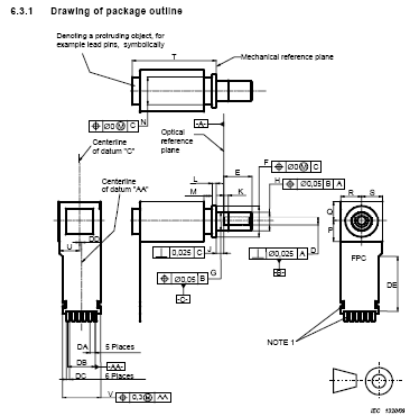

Recommended arrangement for the PCB

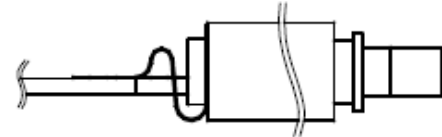
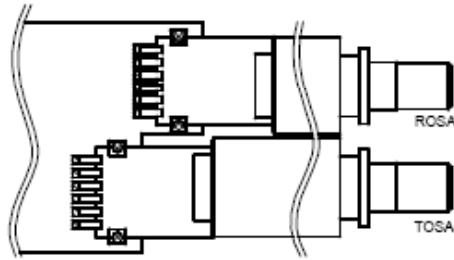

- Standardised package format
- Captures ~80% of current low port PIC projects
- XFP and other electronics package compatible
- Multiple electrical IO (tbd)
- TEC support

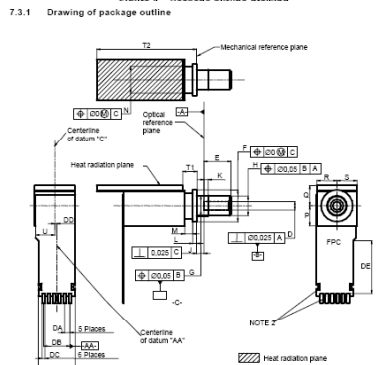

Recommended arrangement for the PCB

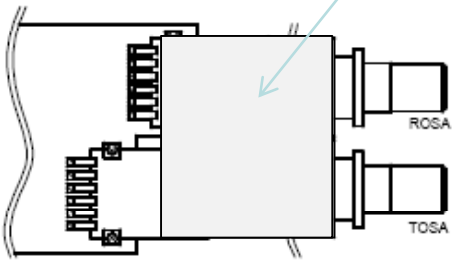

Single package footprint

- Dual TOSA/ROSA footprint package
- PIC support - POSA
  - Supports single/dual fibre port
  - Supports high electrical port count
  - Supports angled facets on PIC

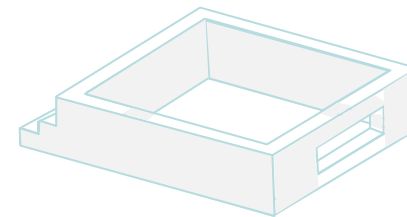
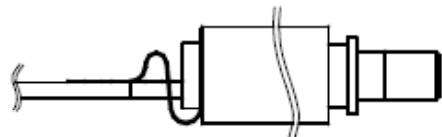
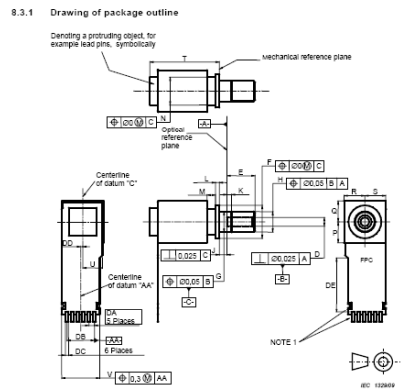

IEC 62148-16

Ref: Packaging Workshop: TU/E Eindhoven 7<sup>th</sup> July 2011

enabling optical technologies

Bob Musk 2011

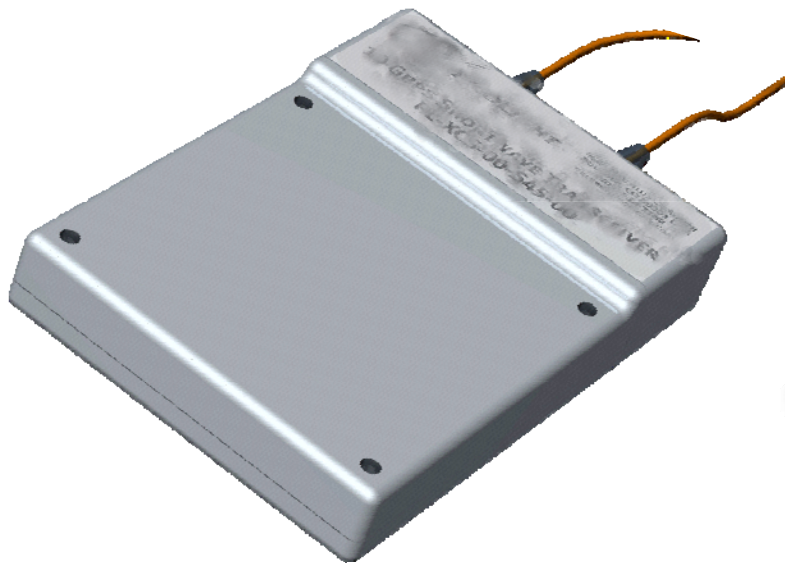

300pin transponder



CFP



XFP

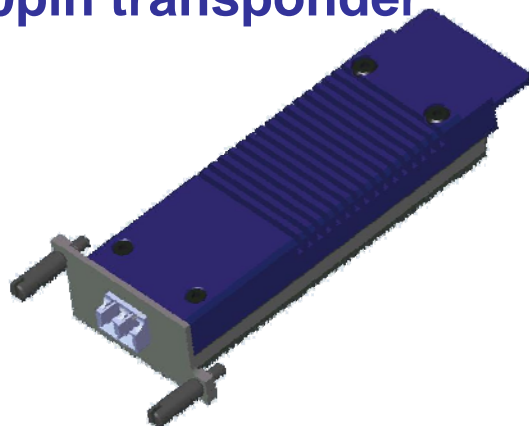

XENPAK

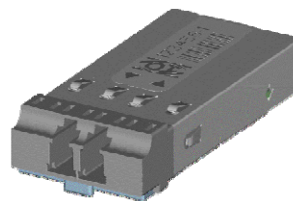

X2, XPAK

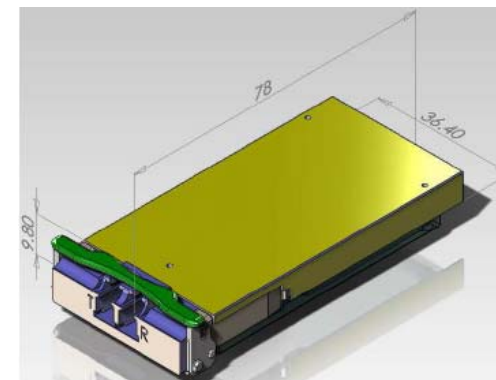

New versions always emerging

**HOT Pluggable receptacle most popular**

enabling optical technologies<sup>3</sup>

# New package features

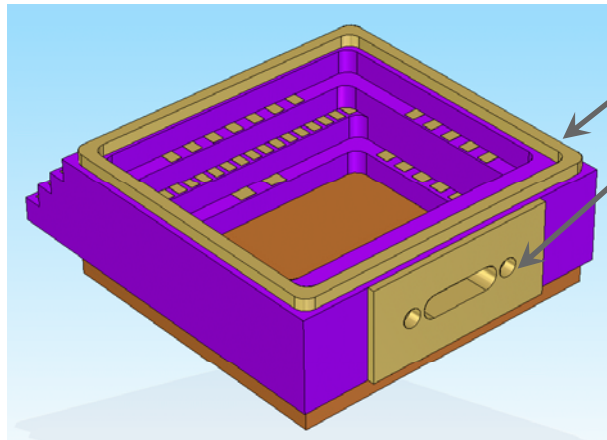

Kovar lid seal ring

Kovar front plate with receptacle attach features

Hermetic AR coated sapphire window

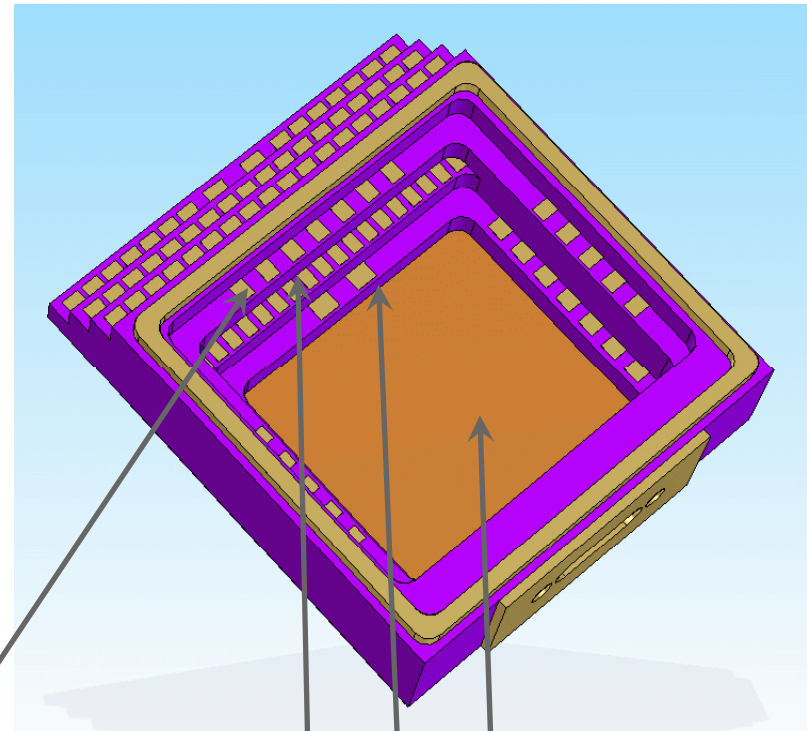
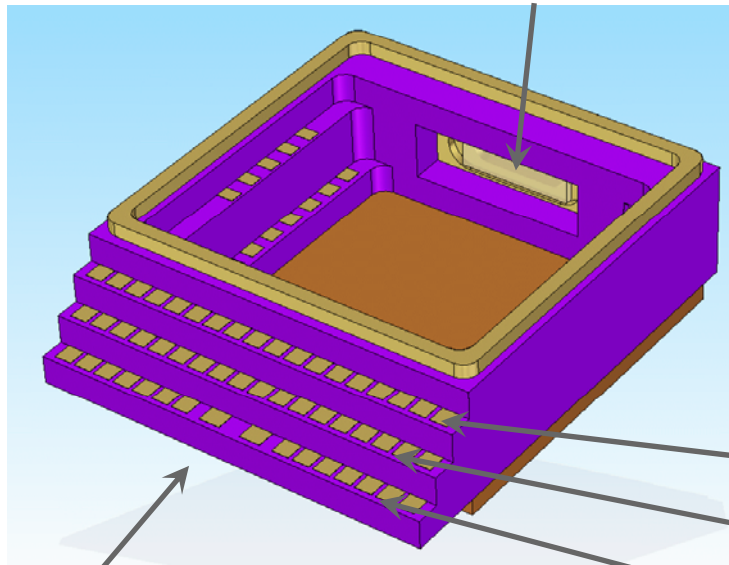

DC/RF electrical connection level

RF electrical connection level

Copper tungsten base

TEC and DC electrical connection level

External interface can support leadframe/flex/wirebonding

Ref: Packaging Workshop: TU/E Eindhoven 7<sup>th</sup> July 2011

enabling optical technologies

Bob Musk 2011



Gooch & Housego

# Package feature detail

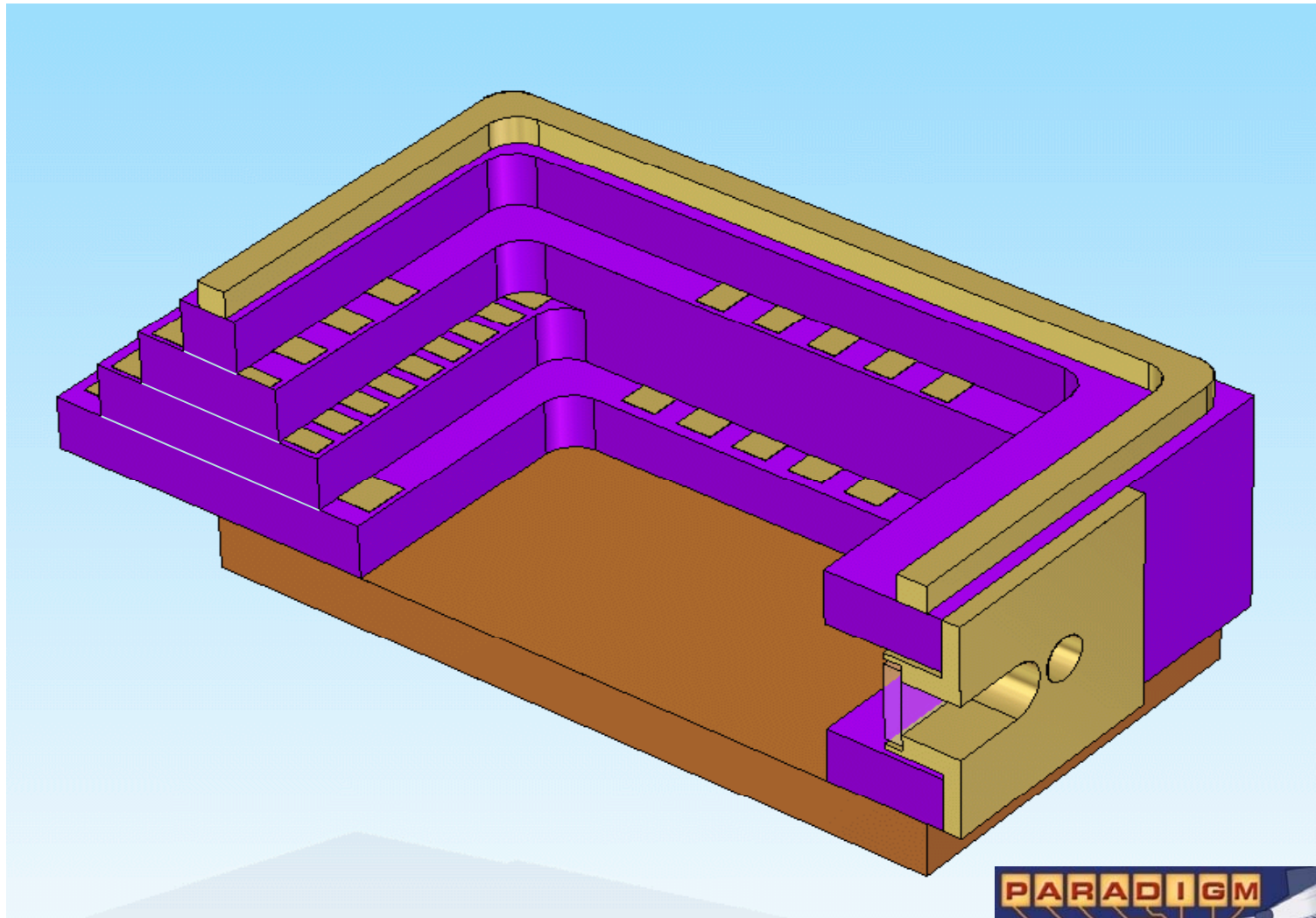

enabling optical technologies



## PARADIGM PIC standardized e/o port positions (low port count draft)

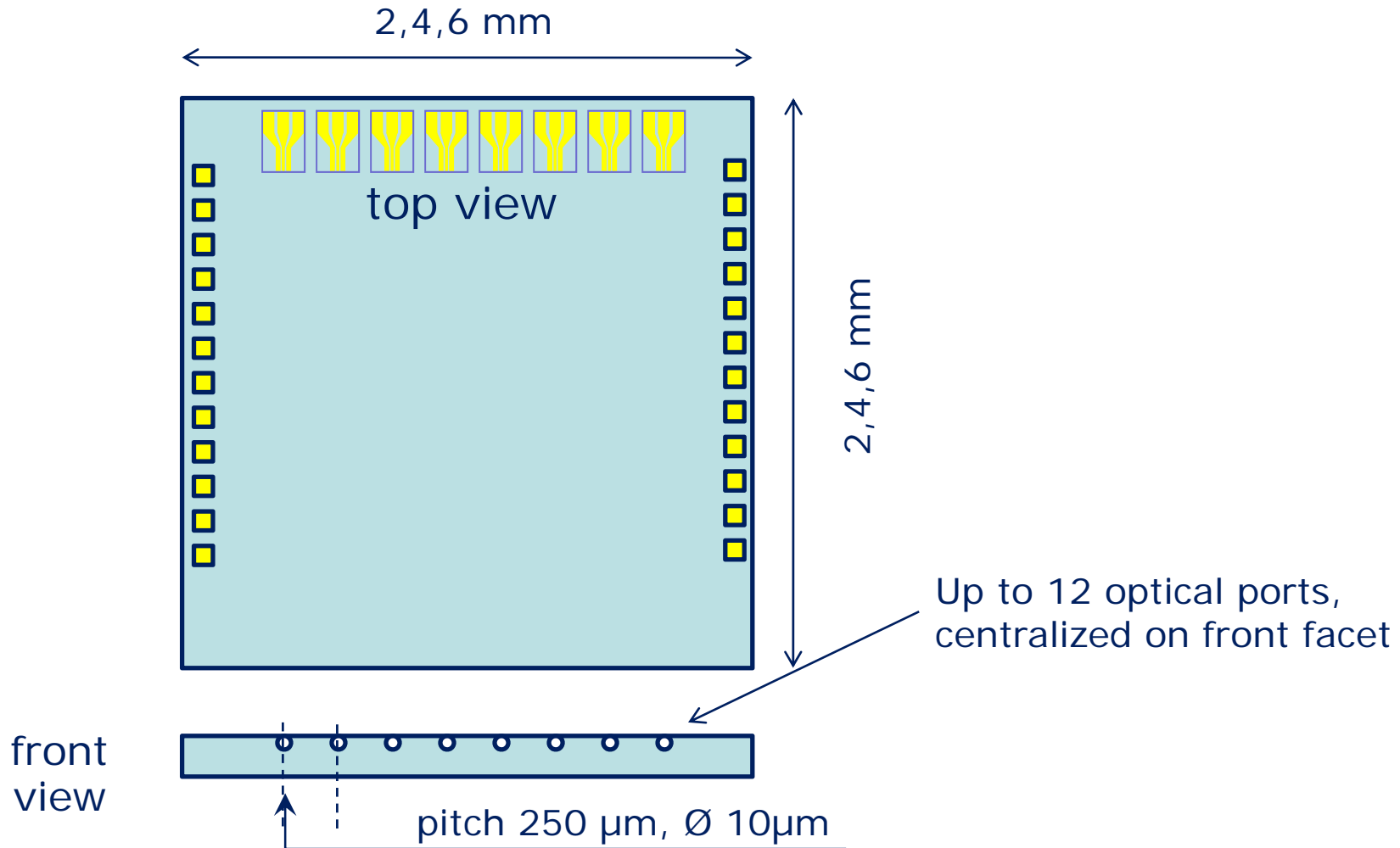

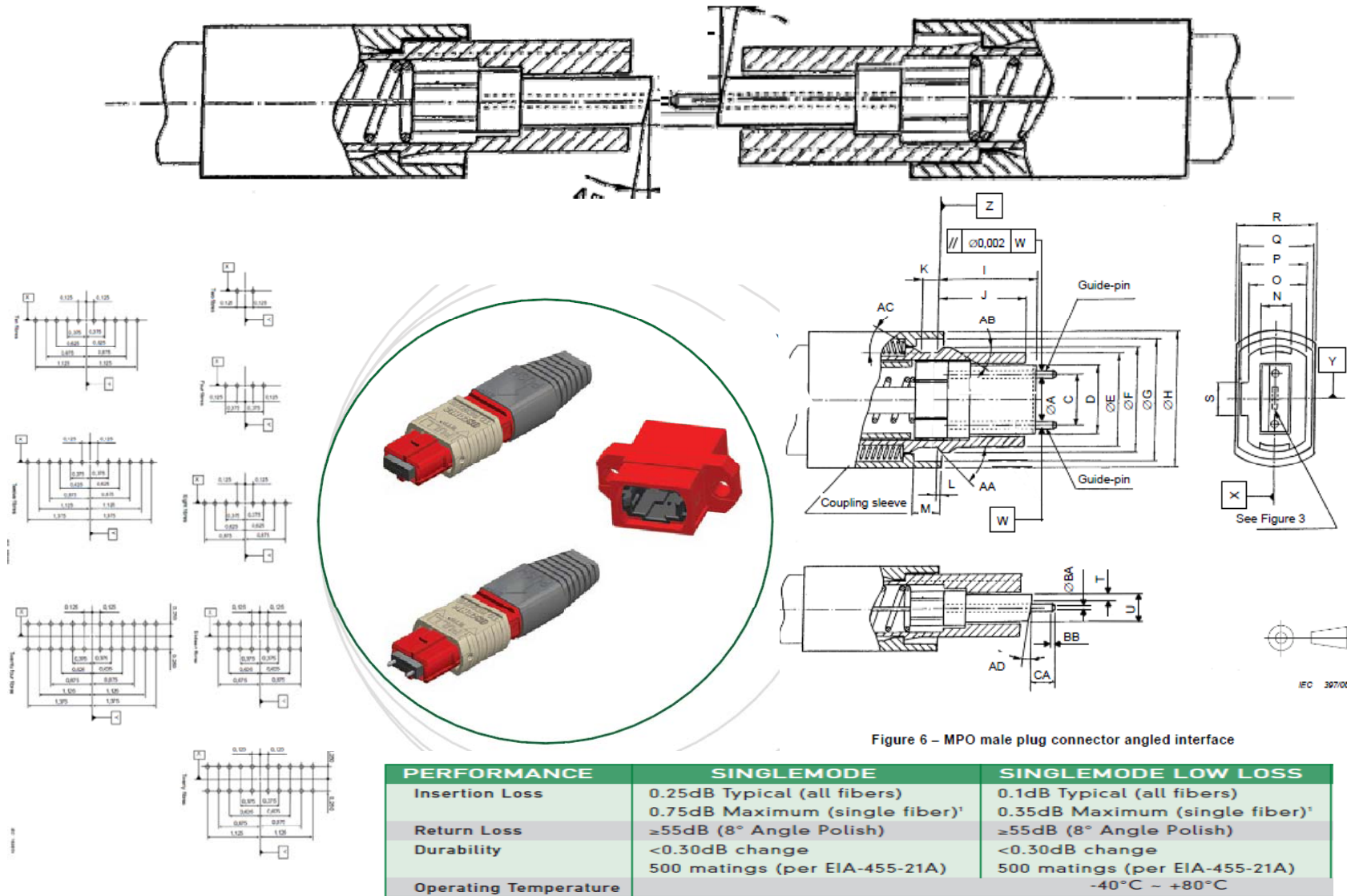

# Ceramic packages

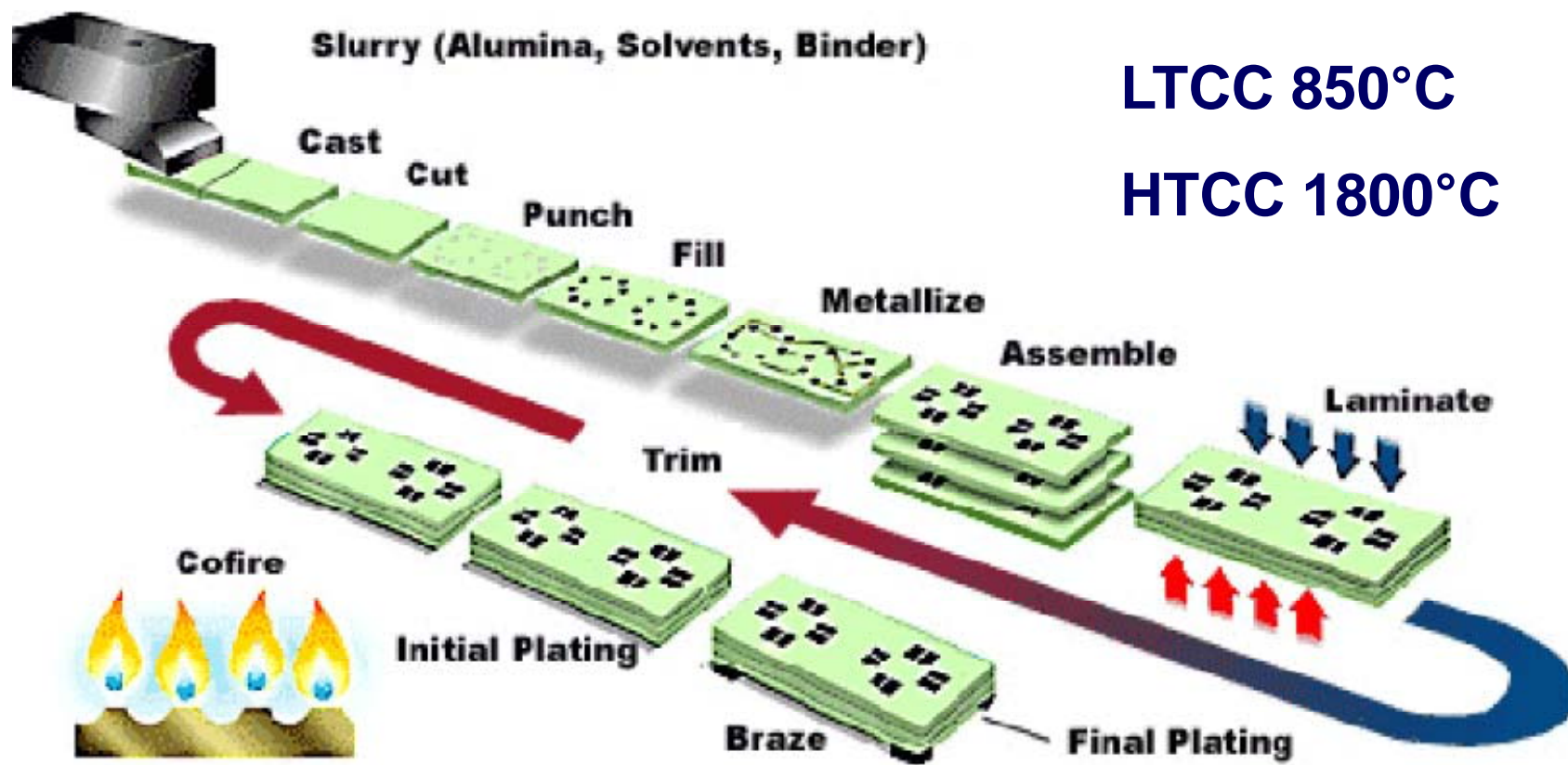

enabling optical technologies

 **Gooch & Housego Typical TOSA/ROSA construction**

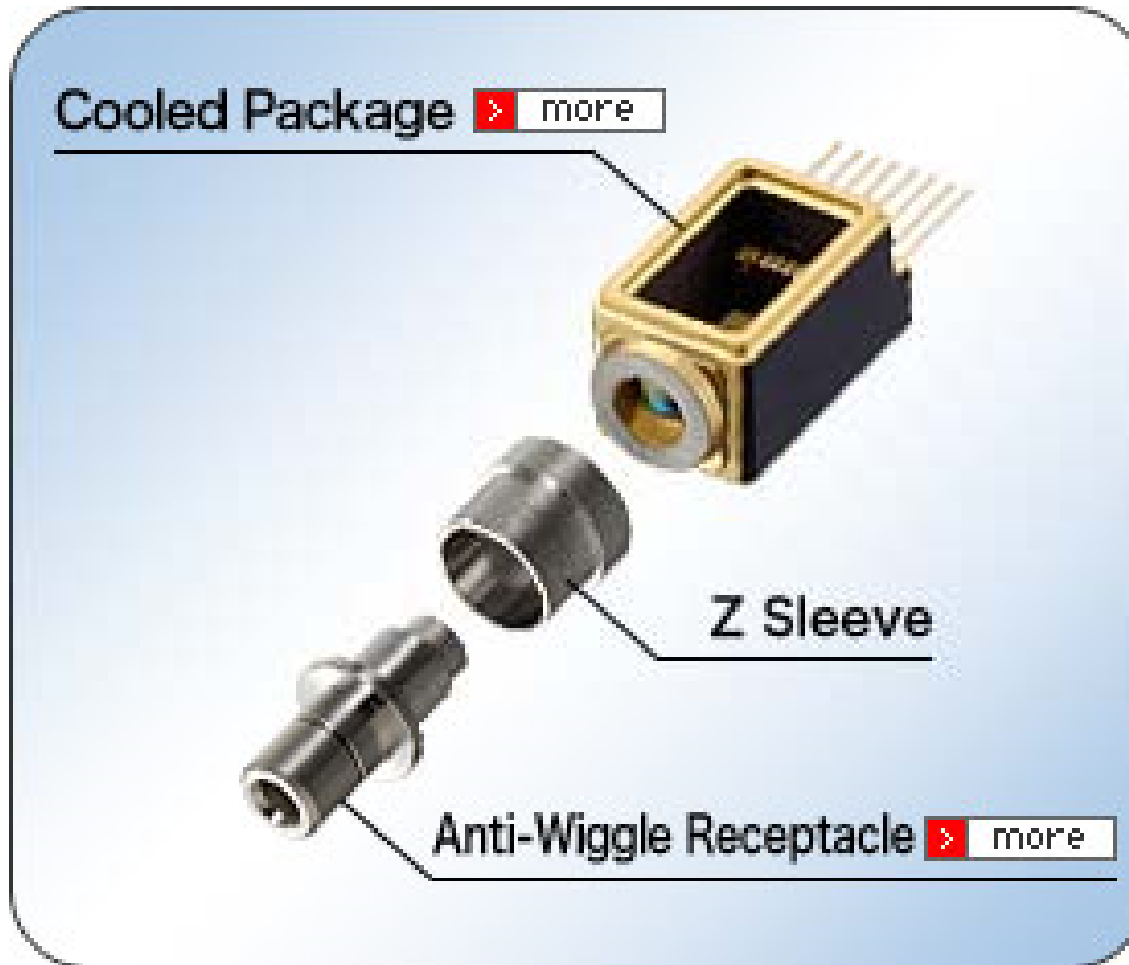

enabling optical technologies

# Optoelectronic packaging

## Design, development and Manufacturing

**What are the options?** enabling optical technologies

# Design/Manufacturing options

- **In-house**
  - Volume capability
  - Standard design approaches
  - Standard process
- **Sub contract**
  - Volume capability
  - Standard processes
- **Niche / specialist**
  - Low/mid volume capability
  - Flexible design and build
  - Extended product range capability
  - Multiple process capability

**Volume capability can limit flexibility** enabling optical technologies

**An example of a niche/specialist**

**Optoelectronics Packaging  
capability**

---

**Gooch and Housego**....enabling optical technologies

# Custom Photonic Packaging

- Actives design, manufacture, test and qualification
- Dedicated expert resources with extensive experience
- Fully equipped, purpose built, antistatic facility certified to ISO 9001/2000 with cleanroom facilities

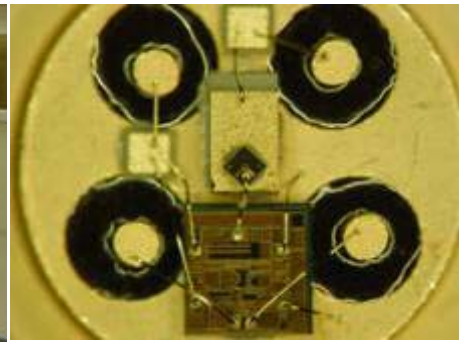
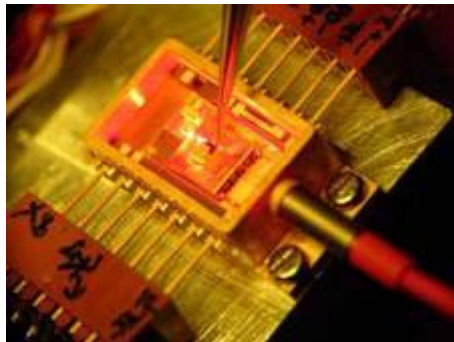

**Comprehensive capability** enabling optical technologies

# Photonics Packaging Philosophy

- Emphasis on custom products
  - Close customer co-operation
  - Experienced design team
  - Design for manufacture
- Target markets
  - Development projects
    - Research devices
    - Prototype to commercial product
  - Small/medium volume complex manufacture
  - Medical/Sensors/Comms/Military/Consumer etc
  - Provides a service that others do not support
    - Because volumes are too small
    - Because design/build problems

**Caters for all markets**

enabling optical technologies

# Design and development

- **Specialist designers of optoelectronic packaging**
  - In-house skill set
  - Custom design
    - Active and passive devices
    - Optical (Zemax support)
    - Mechanical (Solid Edge support etc)
    - Thermal
- **Extensive experience of practical packaging issues**
  - Design for manufacture
  - High speed (10Gb/s +)
  - Stable alignment and PM techniques
  - Thermal management
  - Hermetic design
  - Vacuum packaging
  - Fibre handling
  - Free space products
  - Bulk optics products
  - High Power
  - Single mode and PM RGB

Exceptionally wide product range capability enabling optical technologies

# Manufacture

- Fully equipped for
  - R&D samples (<10)
  - Prototype development (<100)
  - Small/medium volumes (>100)
  - Route for high volume sub-contract manufacture
- Comprehensive capability including
  - Precision die attach – eutectic, solders and epoxy
  - Wirebond – fine/fat wire, tape, Al/Au/Cu, wedge, ball bond, deep access
  - Hybrid assembly
  - Active alignment – sub micron multi-axis capability
  - Bulk optics align/fix capability
  - Special lens capability
  - Stable sub micron active attach technology
  - Micro spot welding, parallel gap welding,
  - Thermode and hot gas micro soldering
  - Induction heating systems
  - Glass sealing for hermetic feedthrough etc
  - Hermetic sealing – projection welding and seam sealing.
  - Laser welding
  - Hermetic fibre feedthroughs
  - Connectorisation
  - Extensive materials and piece-parts instant availability
  - Critical process clean room capability
  - ESD control

**Virtually every packaging process available** enabling optical technologies

## Test and Qualification

- Gooch and Housego has a reputation for the highest quality and reliability
- Broad range of test facilities
  - Optical test
  - Leak test (gross & fine)
  - Burn-in
  - Environmental
- Equipped to undertake full Telcordia 468 and 1221 qualification programmes



**Complete test and qualification capability** enabling optical technologies

## Gooch and Housego Summary

Gooch & Housego is an international group specializing in the manufacture of precision optical, crystal and optoelectronic components for OEM's and research purposes. The Group offers a unique optical manufacturing and design capability making it a first choice manufacturer and technology partner for many of the photonic industry's leading OEM's and scientific institutions.

- Photonics packaging
- High performance fused couplers
- Integrated electronics/photonics module design and manufacture
- Precision Optics
- Optical Coatings
- Acousto Optics
- RF Electronics
- Electro Optics
- Single Crystal Growth